



DIGITAL DMX
PROGRAMMABLE DIMMING CONSOLE
DIRECTOR PLUS

CX-12

USER MANUAL

VERSION 2.02

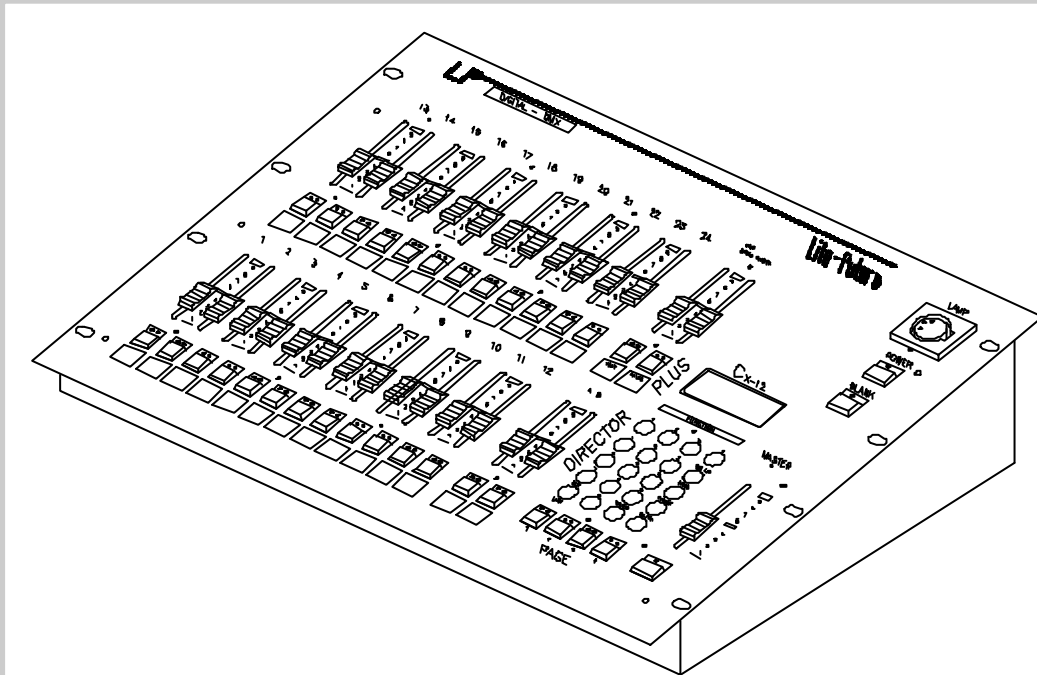



CONTENT

- 1) **BRIEF OPERATION DESCRIPTION**
 - STARTING CHANNEL OPERATION..... 1**
 - CREATING A SCENE..... 3**
 - OPERATING A SCENE..... 4**
 - SETTIING UP A SEQUENCE..... 5**
 - OPERATING CHASE..... 6**
 - A/B CROSS FADERS 7**
- 2) **MAIN FUNCTIONS 8**
- 3) **SETUP OPERATION (FLOW CHART)..... 9**
- 4) **SEQUENCE OPERATION (FLOW CHART)..... 10**
- 5) **GENERAL FUNCTIONS**
 - PRODUCT ILLUSTRATION..... 12**
 - PRODUCT DESCRIPTION..... 13**
- 6) **SYSTEM CONFIGURATION..... 15**
- 7) **SPECIFICATION 16**
- 8) **MAINTENANCE..... 16**

OPERATING DESCRIPTION.....Starting channel operation

A. POWER SUPPLY: 110V~240V AC

B. TURNING POWER ON;

Hardware ac on / off switch on rear panel

software; on/off switch on upper right corner of front panel

C. BLANK KEY; *check led light on blank key. Cx-12 is operational when when light is off.*

D. CHANNEL OPERATION

1. Pull down all the fader VR---->to the bottom

2. Pull down master fader VR---->to the bottom, then press key below.

3. Adjust master fader VR to maxium level.

4. Press **SC/CH** key to enter into channel mode-----> LCD shows:

PAGE START CH01

Check if operation is in Channel mode (2 ways);

1. LCD screen

2. page keys' indication lights: green = channels, red = scene

5. Press page key #1~4, depending on start channel of first fader VR (see below) .

6. Page 1,2,3,4 --> page 1: ch01~24---> LCD shows: PAGE START CH01

page 2: ch25~48---> LCD shows: PAGE START CH25

page 3: ch49~72---> LCD shows: PAGE START CH49

page 4: ch73~96---> LCD shows: PAGE START CH73



Example: How to set the level of the following channels;

Ch#25-----70%

Ch#26-----50%

Ch#01-----100% (fl)

Ch#95-----90%

Steps :

1. Press page 2 (ch25~48) ----->LCD:PAGE START CH25
2. Adjust fader VR #1 to 70% (LCD shows channel level)
3. Adjust fader VR #2 to 50% (LCD shows channel level)
4. Press page 1 (ch01~24) ----->LCD shows:PAGE START CH01
5. Adjust fader VR #1, and #2 to 0% -bottom (LCD shows channel level)
note: ch25 &ch26 will remain unchanged.
6. Adjust fader VR #1 to 100% (fl)
7. Press page 4(ch73~96) ----->LCD: PAGE START CH73
8. Adjust fader VR #1 to 0%
9. Adjust fader VR #23 to 90% (LCD shows channel level)

P.s. : if you want to change the level of ch26 to 40%;

1. Press page 2 (ch25~48) ----->LCD:PAGE START CH25
2. Adjust fader VR #23 to 0%
3. Adjust fader VR #2 to 100%, then down to 40%

TO SET CHANNEL LEVEL TO A SCENE, SEE NEXT PAGE

OPERATING DESCRIPTION..... Creating a scene

A A scene can only be created through the set of channels. See channel operation, or the following example.

B. Set the level of channels desired.

C. Save channels to a scene No.

1. Press PROG key----->LCD shows: 1.Scene 2. Sequence
2. press function key #1(Scene) -----> LCD shows: 1.Load 2.Save 3.Clear 4.More
3. Press function key #2 (Save)
4. Key in the desired scene No. to be saved
(choose from 01~96 on the number keys)
5. Press enter. Scene is displayed

Example: Create scene #1 with the following channels

CH1=100% CH12=100% CH11=100%
CH12=100% CH15~18=100% CH25~30=100%

STEPS

1. Adjust master fader VR to 100%
Make sure the program is in CH mode (see LCD screen), if not press the SC/CH key.
2. Press page #1----->LCD shows: PAGE START CH01
3. Adjust fader VR #1,2,11,12,15~18 to 100%
4. Press page #2----->LCD shows: PAGE START CH25
5. Adjust fader VR #1,2,11,15~18 to 0% - bottom
6. Adjust fader VR #1~6 (CH25~30) to 100%

To save channels' level to scene No.;

7. Press PROG key-----> LCD shows:1.Scene 2.Sequence
8. Press function key #1(Scene)-----> LCD shows :1. Load 2. Save 3. Clear 4. More
9. Press function key #2. (Save)--->LCD shows: SAVE SCENE 01
10. Press desired scene #..... press key numbers #0 and #1
11. Press ENTER. All previous channels are now saved in scene #1 (sc-1)
12. Continue as described above to create up to 96 scenes.

OPERATING DESCRIPTION..... Operating a scene

Scene can be recalled by:

- a. Using keys to load scene #**
- b. Using fader vr to load scene #**

A. USING KEYS TO LOAD SCENE #

First adjust all faderVR to 0%

1. Adjust all channel levels to 0% by adjusting master vr to 0%, then pressing the master key (under the master fader vr)
2. Adjust master vr to 100%
3. Press PROG key ----->LCD shows: 1. Scene 2. Sequence
4. Press function key#1 (Scene)----> LCD shows 1. Load 2. Save
3.Clear 4.More
5. Press function key#1 (Load)----> LCD shows; LOAD SCENE 01
6. Press number keys #0, and #1
7. Press ENTER. Scene #01 is now loaded.

B. USING FADER VR TO LOAD SCENE #

1. Adjust all channel levels to 0% by adjusting master vr to 0%, then pressing the master key (under the master fader vr)
2. Adjust master vr to 100%
3. Press SC/CH key. Red light on page key indicates scene mode. (green light indicates channel mode) ----->LCD shows: PAGE START SC01.
4. Press PAGE 1 key (faders VR#1~24 = Scenes: SC01~SC24).
5. Adjust fader VR #1 to 100%.

OPERATING DESCRIPTION.....Setting up a sequence

Setting a sequence provides the operation for both the chaser and the A/B crossfaders.

A. A sequence can be made only when more than two scenes have been set.

B. Prog----->Scene

↳ ---->Sequence ----->Chaser program (for chaser)

↳ ----->A/B Cross fader

C. Set scene in advance

D. Create a sequence with the scenes.

Note: Sequence programs are used to run chaser program or for the A/B cross fader.

1. Press PROG key----->LCD shows: 1. Scene 2. Sequence

2. Press Function key #2(Sequence)----->LCD shows: 1. Load 2. Save
3.Edit 4.Clear

3. Press function key #3 (Edit) -----> LCD shows: 1.:1 2:+ 3:- 4:E

4. LCD also shows: Sequ.Step01=S(scene)00

A. Key in a desired scene#, previously saved, to step #01.

B. Press ENTER. LCD shows-----> Sequ.Step02=S(scene)00

C. Step#2 is now ready to be entered.

D. Key in a desired scene#, previously saved, to step #02.

E. Press ENTER. LCD shows-----> Sequ.Step03=S(scene)00

F. Step#3 is now ready to be entered.

G. To end sequence: press function #4(E-end)

Note: there are a total of 64 steps possible

5. To save: indicate a # to the sequence program.

A. Press PROG----->LCD shows: 1.Load 2.Save 3.Edit 4.Clear

B. Press function key #2 (Save)

C. Press a No. (01~24) . Example: No. 04

D. Press ENTER. The sequence has been stored in No. 04

OPERATING DESCRIPTION.....Operating chase

Recall a sequence program to operate chase

A. Press CHASER key----->LCD shows: SELECT:F01.....F24

B. Use No. keys (01~24), to select sequence program.

C. Press ENTER

D. Adjust CHASER fader VR to desired level.

E. Adjust SPEED fader VR to the desired level.

Note: If level is at 0%, then speed is automatically controlled by audio.

P.S. To stop chaser operatoion:

1. Adjust CHASER fader VR to 0%

2. Press CHASER key twice.

OPERATING DESCRIPTION..... A/B cross faders

Each cross fader, A and B, can be operated independently.

Each cross fader can operate up to 24 sequences, each with a Total of 64 steps.

(The sequence programs can be loaded by pressing fader VR keys' #1~24 or keying in the number with the No. keys.)

A. Setting speed of fading effect

1. The time of fade in & out of cross fader A or B is controlled by SPEED fader VR.

First: Adjust speed fader VR to desired speed level

Second: Press SPEED key to save speed level.

Note: Speed will not change until SPEED key is pressed again.

B. Manual operation of fading through each step in a sequence program

1. Press PROG key-----→ LCD shows: 1. Scene 2. Sequence
2. Press Function key #2(Sequence)-----→ LCD Shows: 1. Load 2. Save
3.Edit 4. Clear

3. Press function key #1(Load).

4. Hold both cross fader "A" key (or "B" key) and desired program key #

Example : Press Cross fader "A", and fader key #1(PAGE 1)

Crossfader "A" will follow P01 (Program 01).

Note: Every step is a scene previously saved in that program.

5. As cross fader "A" is adjusted to the top position, the brightness of step 01 increase until maximum level at speed rate previously set.
6. Slowly adjust cross fader "A" to lowest position. At this time, step 01 faders out, while step 02 fades in.
7. Continue as above through each step.
8. When all steps have been completed, program automatically restarts with step #1.

B. Button operation

1~3 see steps #1~3 mentioned above in "manual operation".

4. Hold both "A" key (or "B" key) and CH1 key. Crossfader "A" will follow P01 (program 01).

5. Adjust cross fader VR to the top position.

6. Press the fader VR's key to fade through each step at the speed previously set.

7. Continue as above through each step.

Note: To clear "cross fading" operation;

1. *Adjust the cross faders VR to the lowest position.*
2. *Press cross fader VR key(s)*
Output value is at 0%, and operation is at the beginning of the next step.

CX-12 DIRECTOR PLUS

MAIN FUNCTIONS

- 96 CONTROL CHANNELS / 512 PATCH OUTPUT
- 96 PROGRAMMING SCENES
- 24 PROGRAMS FOR CHASING AND CROSS FADER
- EACH PROGRAM FILE CAN BE PROGRAMMED UP TO 64 STEPS
Each step corresponds to a certain scene
- STORES DATA TO EXTERNAL MEMORY (Optional)
- READS AND WRITES DATA IN CONNECTION WITH EXTERNAL MEMORY
- TESTING AND LOCKING ABILITY
- 2 INDEPENDENT CROSS FADERS "A" AND "B"



SETUP OPERATION FLOW CHART

NOTE: PRESS "SETUP" KEY TO RETURN TO PREVIOUS PAGE

SETUP KEY

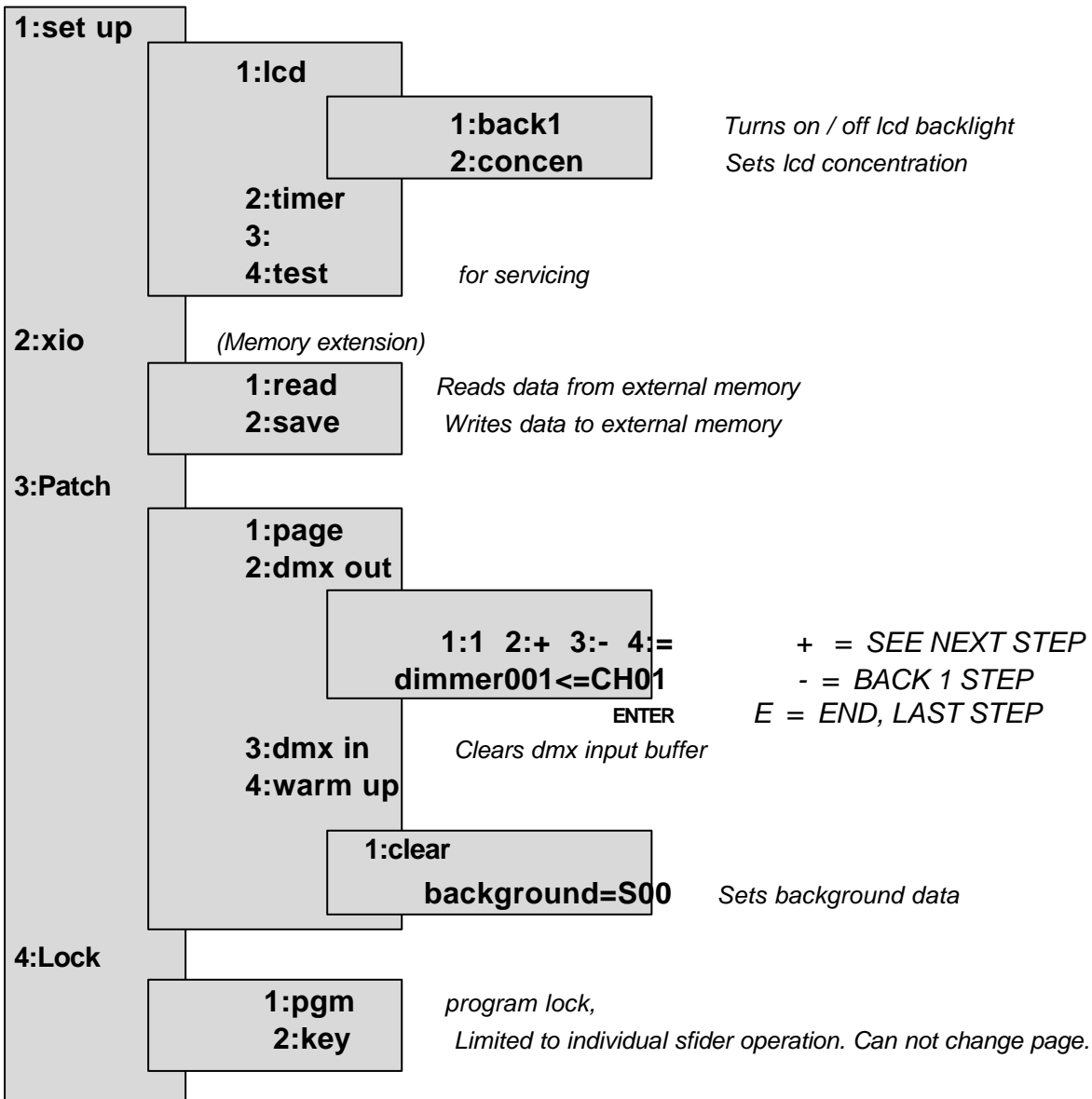

PROGRAMMING OPERATION FLOW CHART

NOTE: PRESS "PROGRAM" KEY TO RETURN TO PREVIOUS DISPLAY

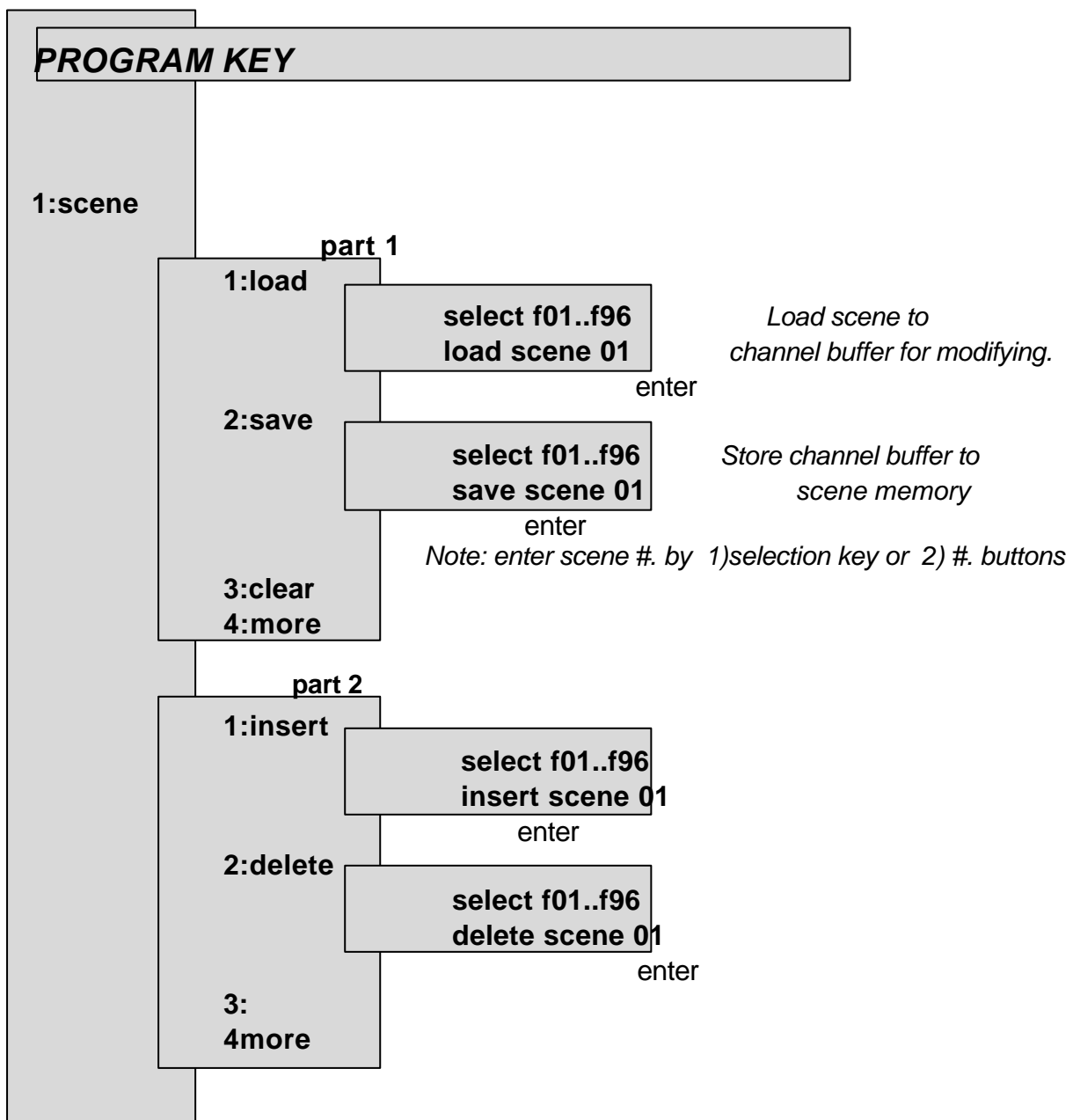

2:program See following page for continuation of programming flow chart

CX-12 DIRECTOR PLUS

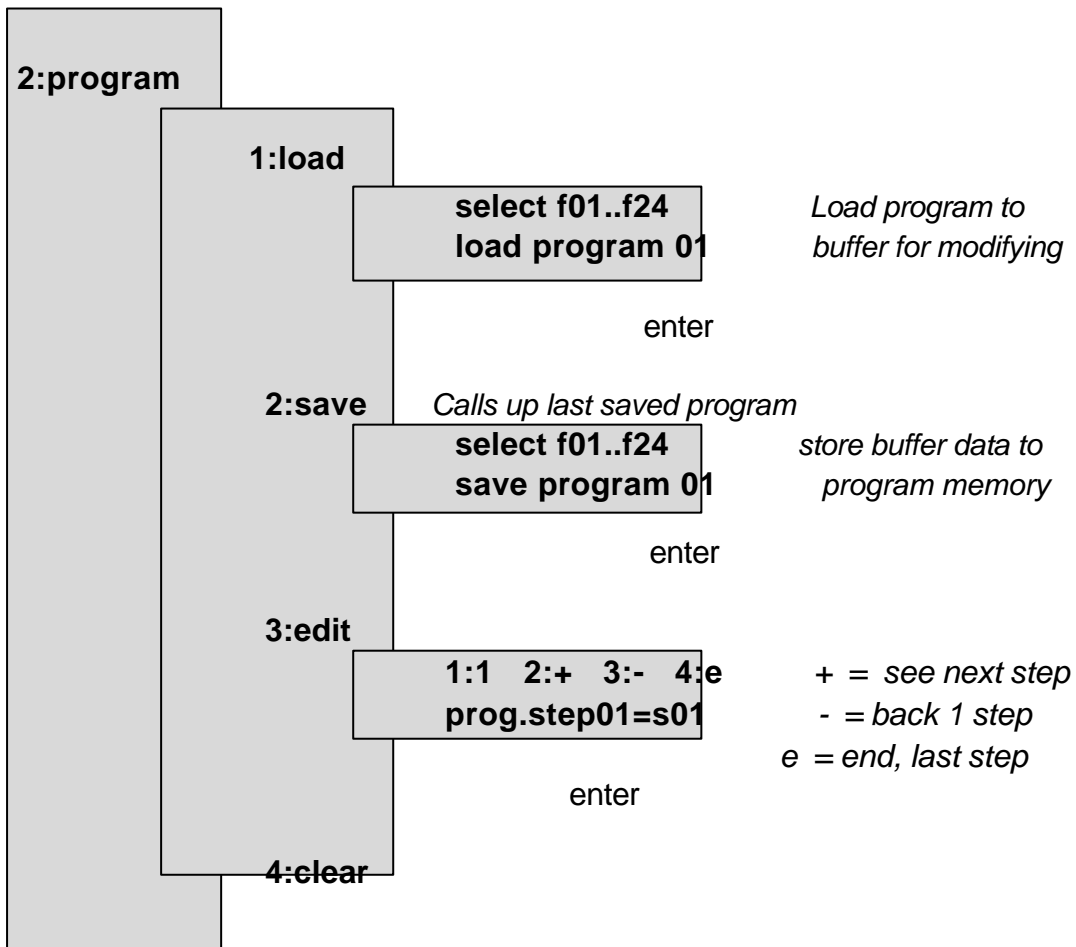
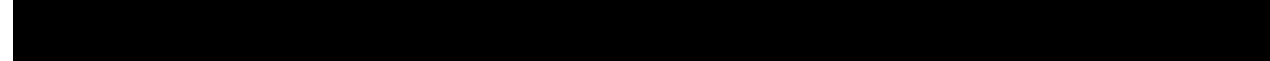

FRONT / REAR PANEL DESCRIPTION

CX-12 DIRECTOR PLUS

FRONT / REAR PANEL DESCRIPTION

[1] *FADER VR #1~24*

[2] *FADER VR #1~24 KEYS (2 Functions)*

A) Flash: individual channel (in Channel mode)

B) Program select (in prog mode) / Scene select (in scene mode)

Note: must push 2x to enter

[3] *DESCRIPTION SPACE (for user to write in)*

[4] *SPEED SLIDER CONTROLLER WITH SELECTION KEY*

Note: At lowest level, switches to audio

[5] *CHASER FADER VR WITH SELECTION KEY*

[6] *FADE "A" FADER VR WITH SELECTION KEY*

[7] *FADE "B" FADER VR WITH SELECTION KEY*

[8] *PAGE SELECTION KEY*

[9] *LAMP CONNECTOR (DC +12V 250mA)*

[10] *POWER SWITCH*

[11] *BLANK SWITCH*

[12] *LCD DISPLAY*

[13] *MASTER FADER VR*

[14] *BUMP KEY*

[15] *FUNCTION KEYS: F1 ~F4*

[16] *SET-UP FUNCTION KEY*

[17] *PROGRAM KEY*

[18] *CHASER KEY 24 CHASING PROGRAMS*

Note: turns off by double click of key button

[19] *SCENE/ CHANNEL KEY*

Note Changes modes: channel <---> scene

[20] *ENTER KEY*

[21] KEY NUMBERS: 0 ~9

[22] CLEAR KEY

[23] EPROM door

Open only to install updated EPROM chip

CX-12 DIRECTOR PLUS

- [24] MAIN POWER SWITCH
- [25] POWER FUSE (.5A)
- [26] AC INPUT
 - Accepts automatically 100~240V 60/50 Hz*
- [27] LAMP POWER SWITCH
- [28] DMX 512 INPUT
- [29] DMX 512 OUTPUT
- [30] ANALOG OUTPUT; 1~10V DC (1~24 CH)
- [31] EXTENDED MEMORY INPUT
- [32] AUDIO INPUT 100mV

CX-12 DIRECTOR PLUS



SYSTEM CONFIGURATION

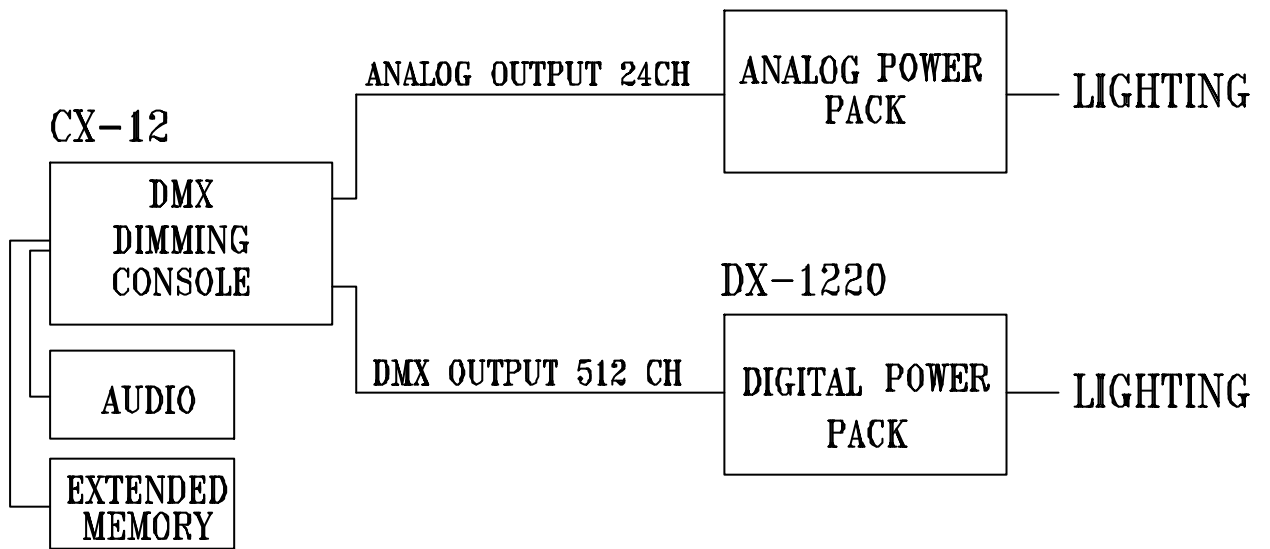

SPECIFICATIONS

POWER SUPPLY	100~240V / 50~60Hz / 0.5A
ANALOG OUTPUT VOLTAGE	0~10V DC
ANALOG OUTPUT CHANNELS	24 CH
	PIN 1~24: CH1~24 / PIN 25: GND
ANALOG CONNECTOR	DB25
DMX OUTPUT/INPUT ..	DMX 512 / 1990 protocol
DMX OUTPUT CHANNELS	512
DMX CONNECTORS	XLR 5-Pin (male and female)
AUDIO SIGNAL LEVEL INPUT ..	Internal microphone (A.G.C.)
	External: 200mV
LAMP CONNECTOR	XLR 3-PIN, DC +25V 250mA
MEMORY CAPACITY	96 CUE (Basic)
DIMENSION	19" 6U Standard rack size
	482mm (w) x 355mm(h) x 125mm(d)

MAINTENANCE

- *Guarantee is void if improperly connected.*
- *Internal repairs to be done by a professional technician.*

LITE-PUTER ENTERPRISE CO., LTD.

P.O. BOX 1-33 HSI-CHIH. TAIPEI HSIEN TAIWAN, R.O.C.

TEL: 886-2-2648-6545

FAX: 886-2-2648-6546

E-MAIL: litecom@ms2.hinet.net

INTERNET: <http://www.liteputer.com.tw>

DOCUMENT: CX-12.DOC. 07/98