

Notes on noise figure measurement and de-embedding device noise figure from lossy input network

Bill Slade
May 2, 2010

Introduction

This brief note reviews the Y-factor method of establishing noise figure and the effects of unmatched input networks on the measurement of device noise figure (i.e. de-embedding the device noise figure from that of the input network, as long as input network losses are not too large).

Finally, a brief look at characterising an input balun for de-embedding a differential device input is given. This method is not suitable for frequencies above 2GHz or so because we rely on placing standard low-tolerance SMD components as reference loads. Above 2-3GHz, parasitics and placement errors will dominate the measurement results. For a quick-and-dirty noise measurement in L or low-S band using a balun, the results may be sufficient for your needs.

Explanation of Y-factor method

Consider the system in Figure 1.

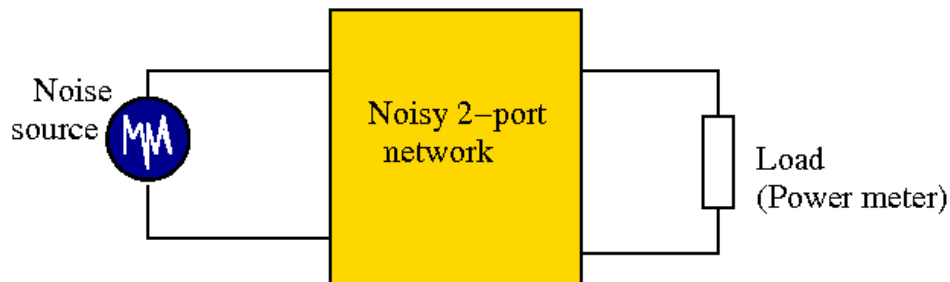

Figure 1: Noisy two-port showing input calibrated noise source and load (measuring device).

If we consider the system to be matched for the noise source in both “on” and “off” states, we assume the power input to the system for the noise-source off state will be the 290K thermal noise

$$P_{off} = kTB$$

and the “on” power to be related to the thermal noise through the designated *Excess Noise Ratio* (ENR) by

$$P_{on} = kTB(ENR + 1).$$

The two port network is assumed to have gain G and noise figure F (generally unknown at this point). Using the additional assumption that the two-port network gain is much larger than the noise figure of the power meter (usually a spectrum analyzer). This means the noise figure of the measuring device does not have a significant impact on the measurement itself (otherwise, the noise contribution of the measuring instrument needs to be determined so its contribution can be removed). Given that many receivers have gains of the order of 60dB or more, spectrum analyzer noise figure is likely to be insignificant in comparison (15-30dB is possible).

Using our power equations, the measured power on the output with the noise source in the off state is

$$P_{out-off} = GFkTB,$$

where F is the unknown noise figure, k is Boltzmann’s constant, T is room temperature (290K) and B is the measurement bandwidth.

With the source switched on, we have

$$P_{out-on} = G(ENR + 1)kTB + (F - 1)GkTB.$$

This can be rearranged as

$$P_{out-on} = GkTB(ENR + F).$$

Forming the ratio of “noise source on” output power to “noise source off” output power yields

$$Y = \frac{P_{out-on}}{P_{out-off}} = \frac{ENR + F}{F}.$$

Solving for the noise figure F yields

$$F = \frac{ENR}{Y - 1}.$$

One can also solve for the gain of the two-port network:

$$G = \frac{Y - 1}{Y} \frac{P_{out-on}}{kTB}.$$

Annex 2: What happens in unmatched cascaded noisy networks?

To answer this, consider the system in Figure 2: an input network and the device, whose noise figure we wish to establish.

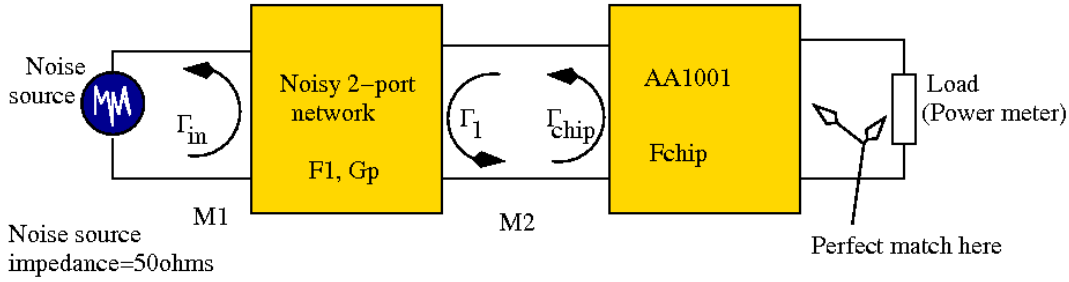

Figure 2: Illustration of cascaded networks that are not necessarily matched.

Specifically, the first two-port network represents the input network that comes before the (possibly differential) LNA input of the receiver module (i.e. SMA connectors, microstrip transmission lines, baluns, etc.). This network is assumed passive, so it will suffer some insertion loss that will contribute to the overall system noise and reduction of gain. The reflection coefficients indicated in Figure 2 are based on a reference impedance (usually 50 ohms). M_1 and M_2 represent the interstage mismatch factors that vary between 0 and 1, if the interface is completely reflective or completely matched, respectively. As shown, these quantities are given by

$$M_1 = \frac{200R_{in}}{|50 + Z_{in}|^2} = 1 - |\Gamma_{in}|^2$$

and

$$M_2 = \frac{4R_1R_{chip}}{|Z_1 + Z_{chip}|^2} = \frac{(1 - |\Gamma_{chip}|^2)(1 - |\Gamma_1|^2)}{|1 - \Gamma_1\Gamma_{chip}|^2}.$$

The variables R_{in} , R_1 , R_{chip} , Z_1 , Z_{chip} are the equivalent input resistance, first stage output resistance, equivalent chip input resistance, first stage output impedance and chip input impedance, respectively. We will continue to normalize everything to 50 ohms by means of the reflection coefficients and S parameters. Resistances and impedances are mentioned here only to show the link with the usual circuit parameters. The noise figures of stages 1 and 2, respectively, are F_1 and F_{chip} .

Following the analysis in [1], if we attach a 50 ohm load at 290K to the input of the system, we can measure an output noise power given by

$$P_{out} = G_p G_{chip} F_{sys} M_1 kTB,$$

where we call F_{sys} the system noise figure (measured by the Y-factor method).

In terms of the noise contributed by the input, first and second stages, the output noise power can be written as

$$P_{out} = G_p G_{chip} F_1 M_1 kTB + G_{chip} M_2 (F_{chip} - 1) kTB.$$

The first term of this expression gives the noise contributed by the 290K source as well as the internally

generated noise referenced to the input of the first stage. The second term gives the contribution of the second (chip) stage to the measured noise at the output, referenced to the input of the second stage. The mismatch factors are necessary because they modify the gain of the stages (by putting the power gain in terms of available input power, i.e. transducer gain). This is because the power gain is defined in terms of full incident power, and not the power that actually “works” (i.e. is transmitted) to drive the stage.

Equating the two preceding expressions and solving for F_{sys} yields

$$F_{sys} = F_1 + \frac{M_2}{M_1 G_p} (F_{chip} - 1).$$

If the first stage is fully passive, the noise figure will be proportional to the loss

$$L = 1 - |S_{11}|^2 - |S_{21}|^2,$$

such that the noise figure of the input network is

$$F_1 = \frac{1}{1 - L},$$

where S_{11} and S_{21} are stage 1 measured S-parameters. Simplifying, we get the noise figure of the passive input network:

$$F_1 = \frac{1}{|S_{11}|^2 + |S_{21}|^2},$$

which reduces to the reciprocal of the network gain in matched situations.

The power gain of stage 1 in unmatched circumstances can be computed as

$$G_p = \frac{(1 - |\Gamma_{chip}|^2) |S_{21}|^2}{(1 - |\Gamma_{in}|^2) |1 - S_{22} \Gamma_{chip}|^2}.$$

Knowing the S parameters of the input network and the reflection coefficient at the input reference plane of stage 2 (the receiver module) and the full system noise figure, the chip noise figure can be extracted using

$$F_{chip} = (F_{sys} - F_1) \frac{G_p M_1}{M_2} + 1.$$

In terms of reflection and S parameter quantities, this means

$$F_{chip} = (F_{sys} - F_1) \frac{|1 - \Gamma_1 \Gamma_{chip}|^2 |S_{21}|^2}{(1 - |\Gamma_1|^2) |1 - S_{22} \Gamma_{chip}|^2} + 1.$$

If the source feeding Stage 1 is defined as 50 ohms, then $\Gamma_1 = S_{22}$. This means

$$F_{chip} = (F_{sys} - F_1) \frac{|S_{21}|^2}{(1 - |S_{22}|^2)} + 1$$

It is interesting that this expression no longer has any dependence on Γ_{in} or Γ_{chip} . This is the same form as the expression for the unmatched cascade noise figure found in [2].

Reviewing the assumptions and required quantities:

1. Source is assumed matched to 50 ohms;
2. First stage (input network) is passive, i.e. F_1 is equivalent to the insertion loss of Stage 1;
3. F_{sys} is measured using Y-method in Section 5;
4. Need to measure S_{11} , S_{21} and S_{22} of the input network to compute Stage 1 insertion loss and de-embedding factor for the chip noise figure.

Annex 3: S parameters of the input balun

Many modern RF devices rely on differential (balanced) RF inputs to minimise coupling to other circuit elements. This requires the use of an input balun, or balanced-unbalanced transformer, because antenna feeds are typically unbalanced transmission systems. For this reason, a method to extract the S-parameters of the balun is needed.

In order to extract the input network S parameters, three reflection coefficient measurements are needed using three known terminations. It is convenient to use a

1. network terminated with short circuit;
2. terminated with matched load;
3. terminated with known mismatch (capacitor, for example).

The open circuit would be convenient, but the effects of field fringing at the open microstrip ends can introduce uncertainty in the measurement, particularly as frequency increases above 1GHz. Note that the measurement setup described here is for use with *in situ* balun measurements without any special connections. Surface mount components are used. This measurement should yield useful values for balun S-parameters for frequencies up to 2-3GHz or so. Above this and component placement errors and parasitics will introduce errors. Moreover, we ignore scattering into the common mode. This will introduce some error, but if the common-mode rejection of the RF device under test is more than 20dB or so, the error will be small and the power scattered into the common mode by the balun will appear as either return loss or insertion loss, adding to the noise on the input. However, for a “quick-and-dirty” measurement on a system PCB without special calibration/de-embedding structures (like TRL), this method can be useful.

Figure 3 shows a block diagram of the measurement setup.

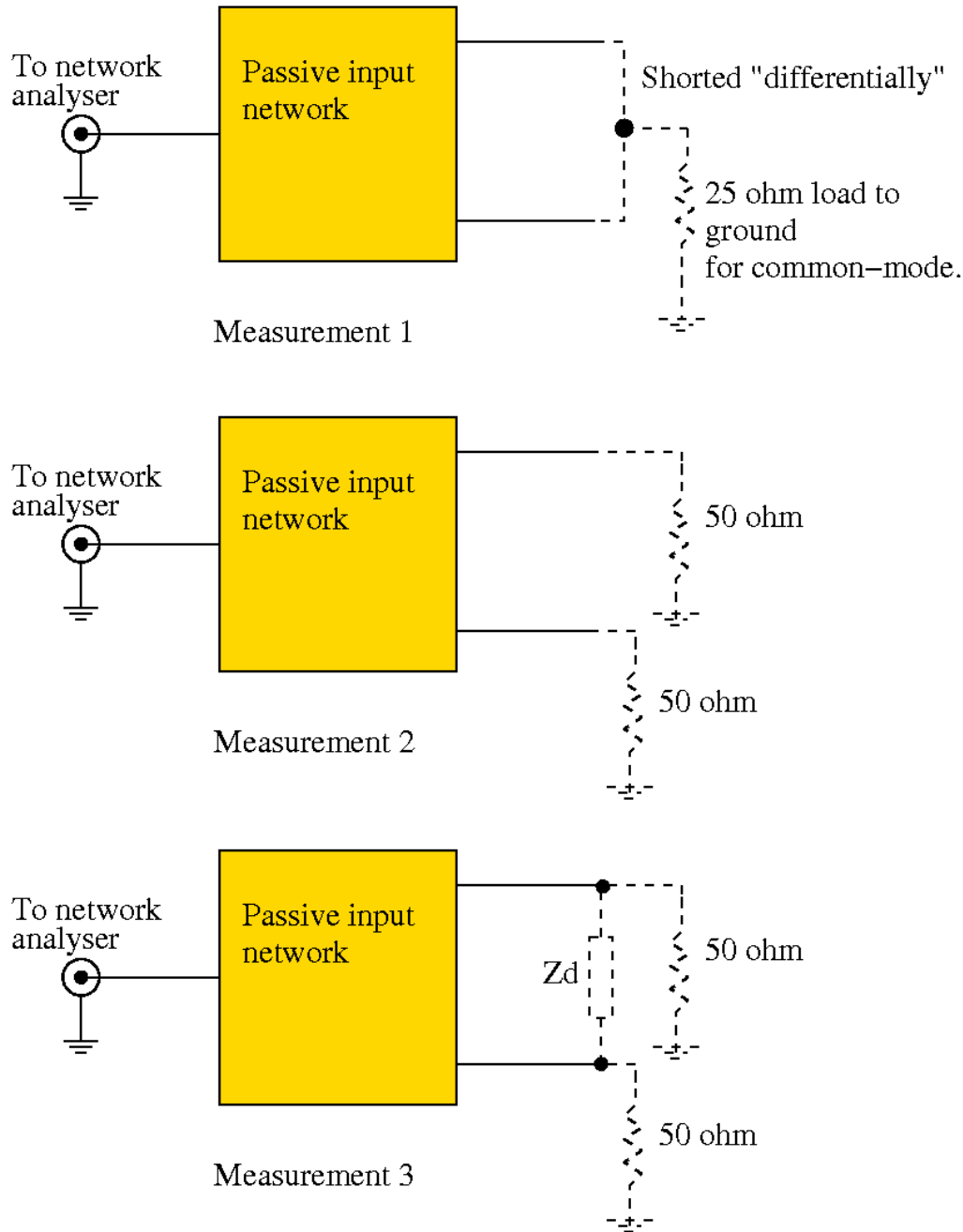

Figure 3: Illustration of measurement setup for extracting equivalent S parameters of input network. The network analyzer connection is unbalanced (single-ended) whereas the loads need to be applied to a balanced line.

Since the signals of interest to many microwave receiver ICs are balanced (differential), the common mode should always be matched. Any power scattered into the common mode by the baluns should appear as loss to the system, and hence will contribute to system noise and gain values (this is what

actually happens in operation). If the balun output is perfectly balanced, the common-mode loading will have no effect. Note that measurement 3 must include the loading of the 50 ohm resistors in differential mode (Z_d in parallel with 100 ohms). This analysis is still somewhat approximate because the even and odd-mode characteristic impedances of the dual microstrip feedline will not be the same because of interline coupling.

Using the expression for input reflection coefficient

$$\Gamma_{in} = S_{11} + \frac{S_{21}S_{12}\Gamma_L}{1 - S_{22}\Gamma_L}$$

with three different load reflection coefficients, we can extract the S parameters measuring the input reflectin with a network analyzer.

Short circuit: $\Gamma_L = -1$

$$\Gamma_s = S_{11} - \frac{S_{12}S_{21}}{1 + S_{22}}$$

Matched load: $\Gamma_L = 0$

$$\Gamma_m = S_{11}$$

Known mismatch: $\Gamma_L = \Gamma_c$

$$\Gamma_x = S_{11} + \frac{S_{21}S_{12}\Gamma_c}{1 - S_{22}\Gamma_c}$$

Using the fact that the input circuit is reciprocal, we know that $S_{21} = S_{12}$. We can then solve for the three unknown S parameters, viz.

$$S_{11} = \Gamma_m$$

$$S_{22} = -\frac{(\Gamma_m - \Gamma_x)/\Gamma_c - \Gamma_s + \Gamma_m}{\Gamma_x - \Gamma_s}$$

$$S_{21} = S_{12} = \sqrt{(\Gamma_m - \Gamma_s)(1 + S_{22})}$$

References

- [1] R. E. Collin, *Foundations of Microwave Engineering*, Second edition, IEEE Press, 2001.
- [2] J. M. Collantes, R. D. Pollard and M. Sayed, "Effects of DUT mismatch on the noise figure characterization: a comparative analysis of two Y-Factor techniques," *IEEE Trans. Instrumentation Meas.*, vol. 51, no.6, Dec. 2002, pp. 1150-1156.